

COMPUERTAS CORTAFUEGO

COMPUERTAS CORTAFUEGO RECTANGULARES



MCR FID-C

MCR FID-P



COMPUERTAS CORTAFUEGO

Las Compuertas Cortafuego MERCOR han sido especialmente diseñadas para compartimentar conductos que pasan por diferentes sectores de incendio tal como exigen las normativas vigentes en materia de protección contra incendios en edificios. Además, las Compuertas mcr FID poseen el marcado CE en cumplimiento del reglamento 305/2011/EU.

APLICACIÓN

- Las compuertas rectangulares mcr FID-C y mcr FID-P han sido diseñadas para ser integradas en sistemas de ventilación, especialmente en zonas de paso de tabiques, tanto vertical, como horizontalmente.
- Durante el fuego, las compuertas previenen la expansión del fuego, las llamas y el humo a través de los conductos de ventilación, permaneciendo aislada la zona contigua del edificio.
- En situaciones normales de operación la compuerta permanece abierta, y en caso de fuego se actúa sobre la clapeta hasta su posición cierre para impedir la propagación del fuego al habitáculo contiguo.

NORMATIVA

- Resistencia al fuego **EIS120** (E=Integridad, I=Aislamiento térmico, S=Estanqueidad de los humos).
- Compuertas cortafuego certificadas según normativa **EN 15650** (Ventilación de edificios, Compuertas Cortafuego), según normativa **EN 13501-4** (Clasificación en función del comportamiento frente al fuego de los productos de construcción y elementos para la edificación) y según normativa **EN 1366-2** (Ensayos de resistencia al fuego de instalaciones de servicio. Parte 2: Compuertas cortafuegos).
- **Marcado CE** con certificados según modelos: mcr-FID-C (**1488-CPD-0203/W, 1396-CPR-0114**), y mcr-FID-P (**1488-CPR-0442/W, 1396-CPR-0103**)

COMPUERTAS CORTAFUEGO

COMPUERTAS CORTAFUEGO RECTANGULARES

DISEÑO

COMPUERTA RECTANGULAR “mcr FID C”

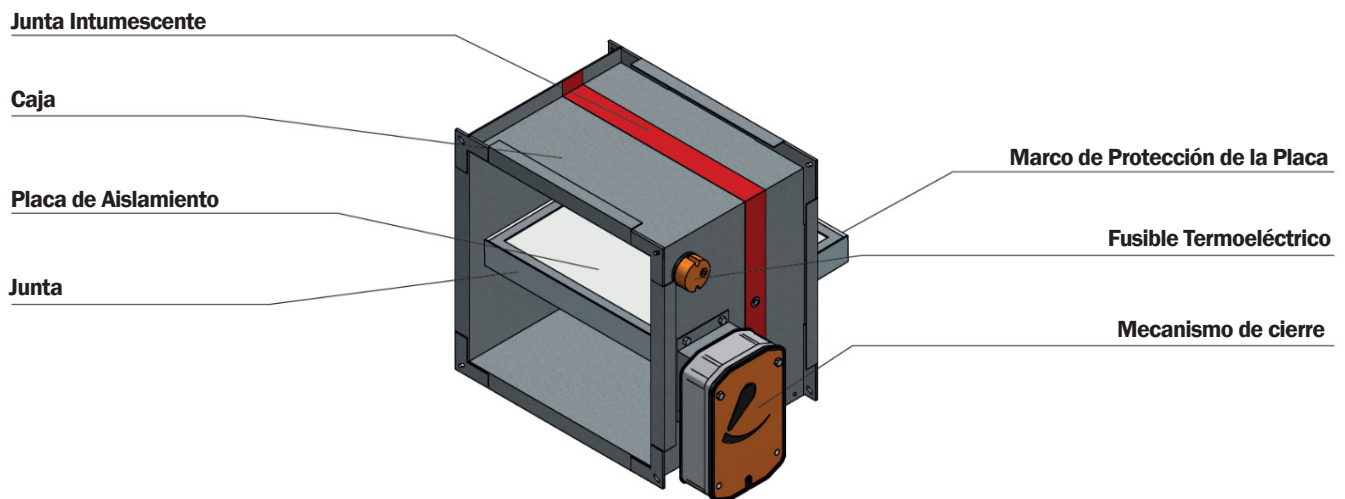

COMPUERTA RECTANGULAR “mcr FID P”

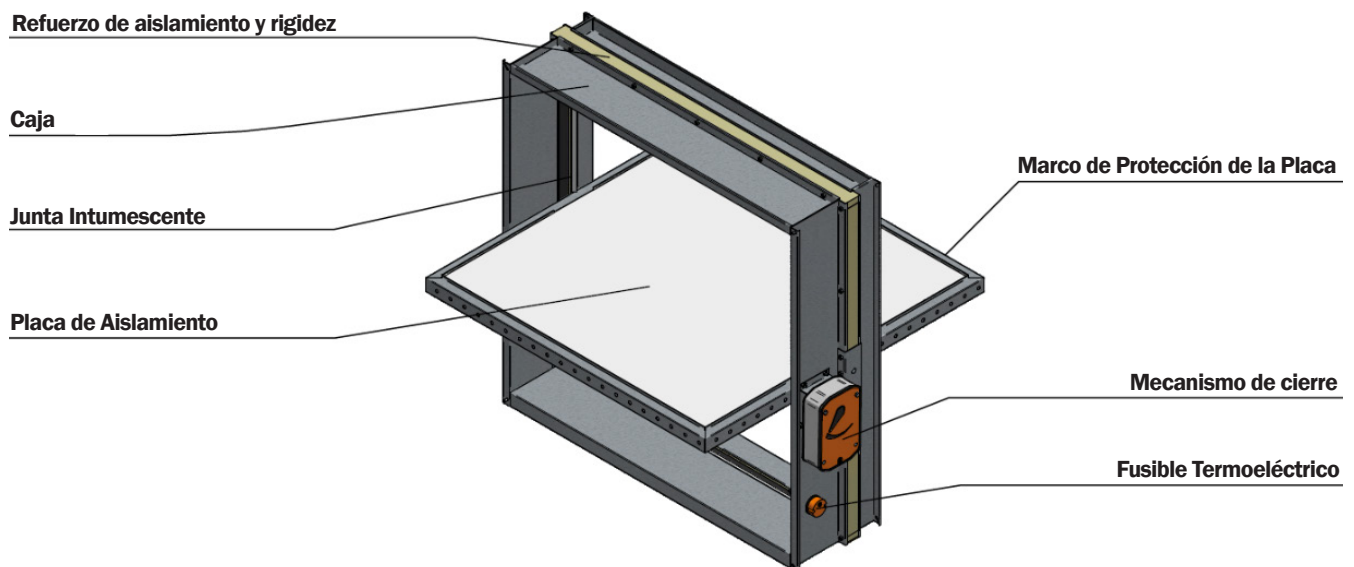



COMPUERTAS CORTAFUEGO

COMPUERTAS CORTAFUEGO RECTANGULARES

MECANISMOS DE DISPARO

Además del mecanismo de actuación manual, las compuertas cortafuego se pueden suministrar accionadas por otros mecanismos de tipo eléctrico. En estos casos la compuerta puede actuar por un doble sistema: mediante fusible térmico o mediante accionamiento electro-mecánico.

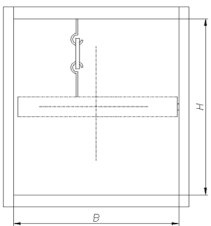
Tipos de accionamiento:

DISPOSITIVO	DESCRIPCIÓN
	RST Fusible térmico (tipo bimetal)
	RST / WK1 Fusible térmico bimetalico y contactos (1x NO + 1x NC) de señal de compuerta cerrada
	RST / WK2 Fusible térmico bimetalico y contactos (1Xno + 1xnc) de señales tanto de compuerta abierta como de cerrada
	RST-KW1/S Con fusible térmico bimetalico 74 ° + manivela de rearme
	RST-KW1/S/WK2 Fusible térmico 74° + manivela de rearme + contactos final de carrera (2 X NO / NC)
	RST-KW1/24I Fusible térmico 74° + manivela de rearme + contactos final de carrera (2 X NO / NC) + sistema de cierre por pulso eléctrico de 24 Volt C.C.
	RST-KW1/24P Fusible térmico 74° + manivela de rearme + contactos final de carrera (2 X NO / NC) + sistema de cierre por corte de tensión (24 Volt c.c.)
	RST-KW1/230I Fusible térmico 74° + manivela de rearme + contactos final de carrera (2 X NO / NC) + sistema de cierre por pulso eléctrico de 230 Volt A.C.
	RST-KW1/230P Fusible térmico 74° + manivela de rearme + contactos final de carrera (2 X NO / NC) + sistema de cierre por corte de tensión (230 Volt A.C)
	BLF24-T Actuador eléctrico alimentado a 24 Volt C.C./A.C. con un consumo de 2,5 w. en reposo y 7 w. en funcionamiento y dispositi-vo de disparo termo eléctrico con contactos auxiliares (2 X SPDT) cuando la compuerta alcanza los 5° y 80°. (par motor 6 Nm Y par de retorno muelle 4 Nm)
	BFL230-T Actuador eléctrico alimentado a 220 Volt C.C./A.C. con un consumo de 3 w. en reposo y 5 w. en funcionamiento y dispositivo de disparo termo eléctrico con contactos auxiliares (2 X SPDT) cuando la compuerta alcanza los 5° y 80°. (par motor 6 Nm. Y par de retorno muelle 4 Nm.
	BFN24-T Actuador eléctrico alimentado a 24 Volt C.C./A.C. con un consumo de 1,4 w. en reposo y 4 w. en funcionamiento y dispositi-vo de disparo termo eléctrico con contactos auxiliares (2 X SPDT) cuando la compuerta alcanza los 5° y 80°. (par motor 9 Nm. y par retorno muelle 7 Nm.
	BFN230-T Actuador eléctrico alimentado a 220 Volt. C.C./A.C. con un consumo de 2,1 w. en reposo y 5 w. en funcionamiento / y dispositivo de disparo termo eléctrico con contactos auxiliares (2 X SPDT) cuando la compuerta alcanza los 5° y 80° (par motor 9 Nm. y par de retorno muelle 7 Nm.
	BFL24-T Actuador eléctrico alimentado a 24 Volt C.C./A.C. con un consumo de 0,7 w. en reposo y 2,5 w en funcionamiento y dispositi-vo de disparo termo eléctrico con contactos auxiliares (2 X SPDT) cuando la compuerta llega a 5° y 80°. (par motor 4 Nm. Y par de retorno muelle 3 Nm.
	BFL230-T Actuador eléctrico alimentado a 220 Volt. C.C./A.C. con un consumo de 1,1 w. en reposo y 3,5 w. en funcionamiento y dispositivo de disparo termo eléctrico con contactos auxiliares (2 x SPDT) cuando la compuerta llega a 5° y 80° (par motor 4 Nm. Y par de retorno muelle 3 Nm.

COMPUERTAS CORTAFUEGO

COMPUERTAS CORTAFUEGO RECTANGULARES

DIMENSIONES

COMPUERTA RECTANGULAR “mcr FID C”

- Ancho nominal B: desde 200 mm. a 800 mm.
- Alto nominal H: desde 200 mm. a 400 mm.
- Superficie máxima de paso por Compuerta hasta 0,32 m².

Dimensiones en función del mecanismo utilizado:

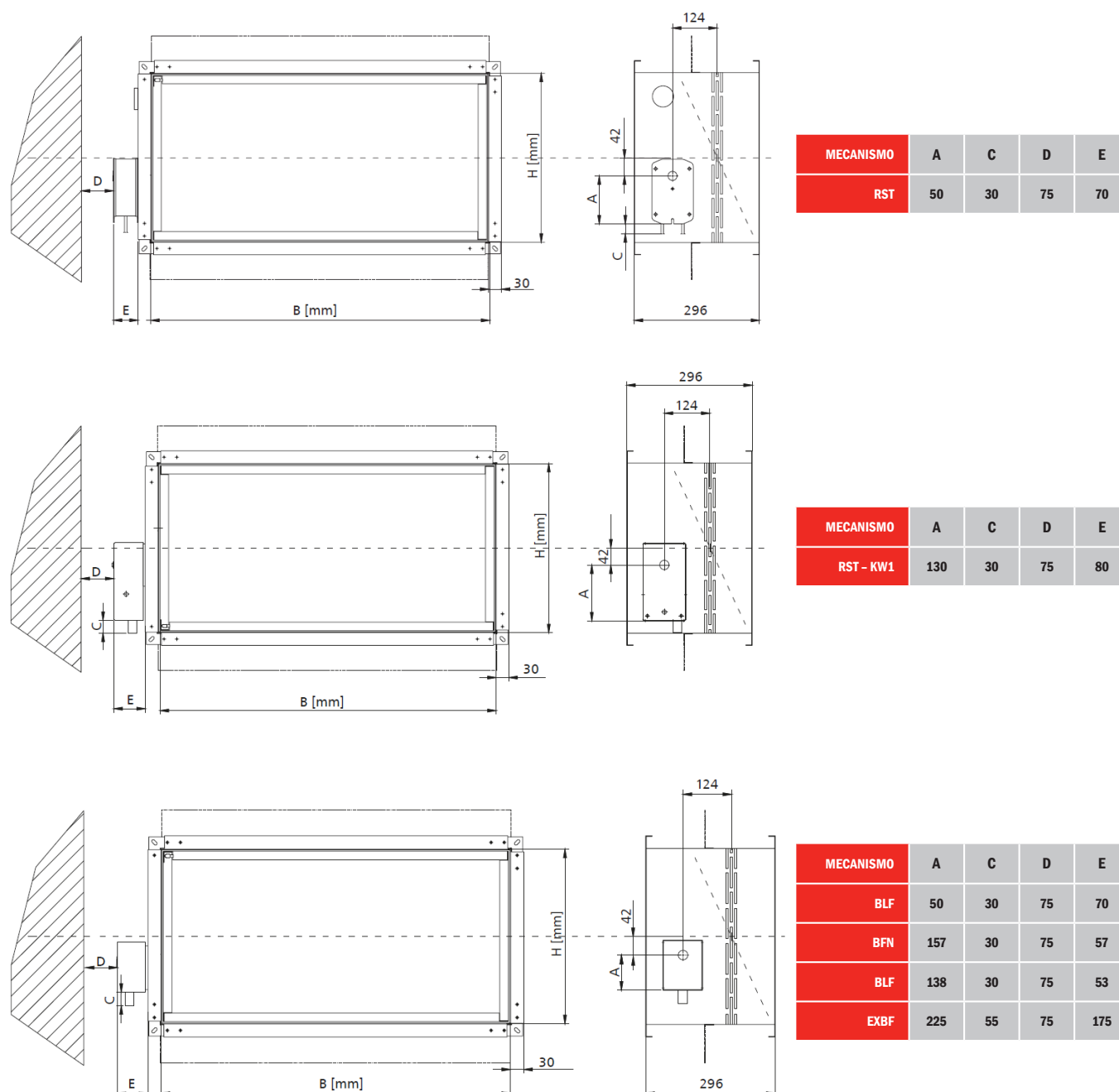

COMPUERTAS CORTAFUEGO

COMPUERTAS CORTAFUEGO RECTANGULARES

DIMENSIONES

COMPUERTA RECTANGULAR “mcr FID P”

- Ancho nominal B: desde 200 mm. a 1500 mm.
- Alto nominal H: desde 200 mm. a 1500 mm.
- Superficie máxima de paso por Compuerta hasta 1,8 m2.

Dimensiones en función del mecanismo utilizado:

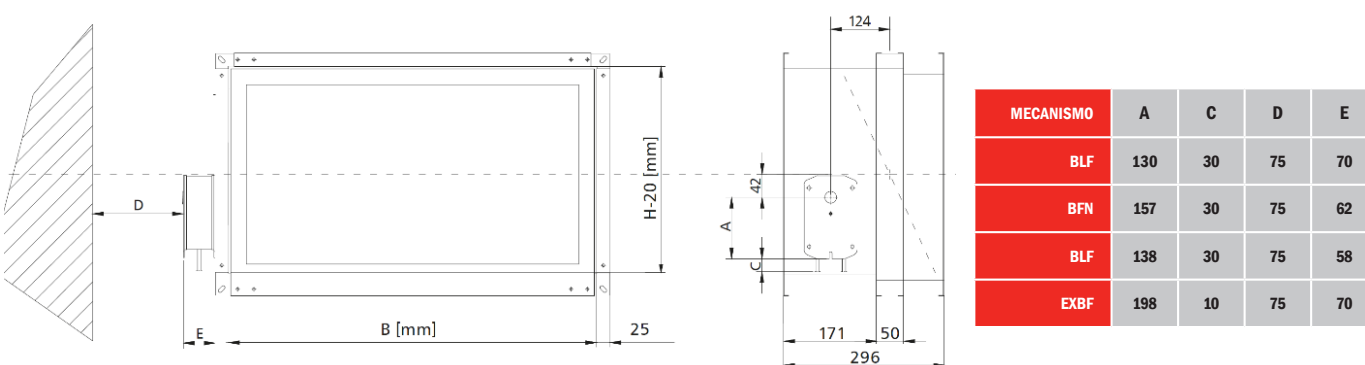
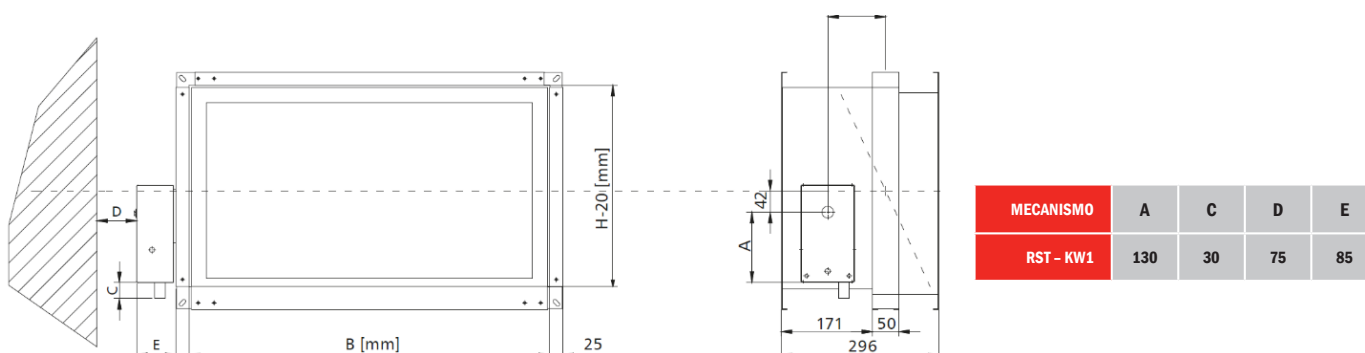
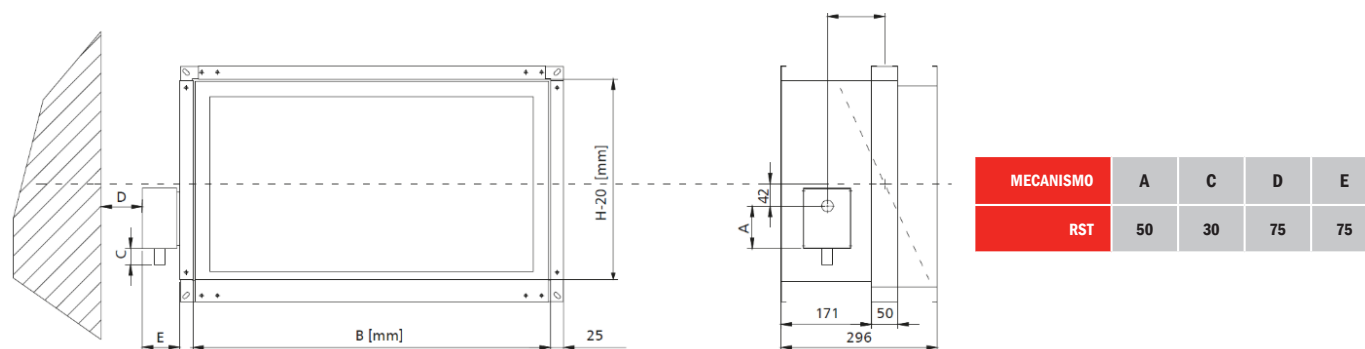

COMPUERTAS CORTAFUEGO

COMPUERTAS CORTAFUEGO RECTANGULARES

PESO ESTIMADO COMPUERTAS

COMPUERTA RECTANGULAR “mcr FID C”

Peso en función de las dimensiones del conducto (Kg):

		Ancho B (mm)							
		200	250	300	400	500	600	700	800
Altura H (mm)	200	7,5	8	9	10	11	14	16	18
	250	8	9,5	10	11	14	15	17	19
	300	9	10,5	11	12	15	16	18	20
	350	10	11,5	12	13	16	17	19	21
	400	11	12,5	13,5	14	18	19	21	22

COMPUERTA RECTANGULAR “mcr FID P”

Peso en función de las dimensiones del conducto (Kg):

		Ancho B (mm)														
		200	250	300	400	500	600	700	800	800	800	800	800	800	800	
Altura H (mm)	200	9,5	9,7	10	10	15	17	17,5	19	22	25	28	30	33	39	45
	250	9,5	10	11	11	16	17,5	18	21	24	27	29	32	34	45	48
	300	10	11	11	12	17	20	21	23	26	28	31	34	38	50	51
	350	11	11	11	16	18	20,5	23	26	28	29	33	35	36	52	53
	400	10	11	12	18	19	21	25	29	30	33	35	36	39	54	55
	500	15	16	17	19	20	23	27	32	33	35	38	40	44	55	56
	600	17	17,5	20	21	30	30	30	35	37	39	43	48	52	56	58
	700	17,5	18	21	23	30	35	35	40	42	44	47	52	54	57	65
	800	20	21	22	24	29	35	37	41	43	49	52	57	60	62	78
	900	22	25	25	28	33	35	39	43	47	53	56	60	62	64	82
	1000	23	29	28	33	36	42	43	49	53	56	59	65	67	69	98
	1100	26	30	31	35	38	42	47	56	59	62	63	69	71	73	101
	1200	32	33	35	36	40	49	53	56	61	71	72	73	85	86	105
	1300	39	40	38	39	44	52	57	59	78	79	80	81	92	-	-
	1400	-	-	48	39	48	56	63	65	80	82	85	87	-	-	-
1500	-	-	50	50	52	58	68	71	82	98	115	120	-	-	-	

NOTA: Para Compuertas sin actuador restar 1 Kg.

COMPUERTAS CORTAFUEGO

COMPUERTAS CORTAFUEGO RECTANGULARES

PARÁMETROS TÉCNICOS

COMPUERTA RECTANGULAR “mcr FID C”

B – Ancho Nominal [mm]

H – Alto Nominal [mm]

Se – Sección útil de la compuerta [m²]

v – velocidad [m/s]

Sk – Sección de los conductos [m²]

L_{WA} – Nivel de Presión sonora [dB]

Q – Caudal [m³/h]

dp – Caída de Presión [Pa]

B [mm]	v [m/s]	H [mm]														
		200					250					300				
		Sk [m ²]	Se [m ²]	Q [m ³ /h]	dp [Pa]	L _{WA} [dB]	Sk [m ²]	Se [m ²]	Q [m ³ /h]	dp [Pa]	L _{WA} [dB]	Sk [m ²]	Se [m ²]	Q [m ³ /h]	dp [Pa]	L _{WA} [dB]
200	4	0.04	0.033	468	7	27	0.05	0.043	612	6	26	0.06	0.053	756	6	28
	6			702	15	37			918	13	37			1134	13	38
	8			936	26	45			1224	24	45			1512	22	44
	10			1170	41	51			1530	37	50			1890	34	50
250	4	0.05	0.041	585	6	27	0.0625	0.053	765	6	27	0.075	0.066	945	5	26
	6			878	14	37			1148	13	38			1418	11	37
	8			1170	24	45			1530	23	45			1890	20	44
	10			1463	38	50			1913	36	51			2363	31	50
300	4	0.06	0.049	702	6	27	0.075	0.064	918	6	28	0.09	0.079	1134	4	26
	6			1053	13	38			1377	13	38			1701	10	36
	8			1404	24	45			1836	22	46			2268	18	44
	10			1755	37	51			2295	35	51			2835	28	49
350	4	0.07	0.057	819	6	27	0.0875	0.074	1071	5	27	0.105	0.092	1323	4	25
	6			1229	13	38			1607	11	37			1985	9	35
	8			1638	22	45			2142	20	45			2646	16	43
	10			2048	35	51			2678	31	50			3308	25	49
400	4	0.08	0.065	936	5	27	0.1	0.085	1224	4	25	0.12	0.105	1512	4	24
	6			1404	12	38			1836	9	35			2268	8	34
	8			1872	22	45			2448	17	43			3024	14	42
	10			2340	34	51			3060	26	49			3780	22	47
450	4	0.09	0.073	1053	5	27	0.1125	0.096	1377	3	22	0.135	0.118	1701	3	23
	6			1580	11	37			2066	7	33			2552	7	33
	8			2106	20	45			2754	13	40			3402	13	41
	10			2633	31	50			3443	20	46			4253	20	47
500	4	0.1	0.081	1170	4	26	0.125	0.106	1530	3	23	0.15	0.131	1890	3	23
	6			1755	10	36			2295	8	34			2835	7	34
	8			2340	18	44			3060	13	41			3780	13	41
	10			2925	28	50			3825	21	47			4725	20	47
550	4	0.11	0.089	1287	4	25	0.1375	0.117	1683	3	23	0.165	0.144	2079	3	22
	6			1931	9	36			2525	7	33			3119	6	33
	8			2574	17	43			3366	13	41			4158	12	40
	10			3218	26	49			4208	20	47			5198	18	46
600	4	0.12	0.098	1404	3	21	0.15	0.128	1836	3	20	0.18	0.158	2268	2	20
	6			2106	7	32			2754	6	31			3402	5	31
	8			2808	12	39			3672	10	38			4536	10	38
	10			3510	19	45			4590	16	44			5670	15	44
650	4	0.13	0.106	1521	3	22	0.1625	0.138	1989	3	21	0.195	0.171	2457	2	20
	6			2282	7	32			2984	6	31			3686	5	30
	8			3042	12	40			3978	10	39			4914	9	38
	10			3803	19	46			4973	16	45			6143	14	44
700	4	0.14	0.114	1638	3	21	0.175	0.149	2142	2	20	0.21	0.184	2646	2	19
	6			2457	6	32			3213	5	31			3969	5	30
	8			3276	12	39			4284	10	38			5292	8	37
	10			4095	18	45			5355	15	44			6615	13	43
750	4	0.15	0.122	1755	3	21	0.1875	0.159	2295	2	20	0.225	0.197	2835	2	20
	6			2633	6	31			3443	5	31			4253	5	30
	8			3510	11	39			4590	10	38			5670	8	38
	10			4388	17	45			5738	15	44			7088	13	43
800	4	0.16	0.130	1872	2	20	0.2	0.170	2448	2	20	0.24	0.210	3024	2	19
	6			2808	5	30			3672	5	30			4536	4	29
	8			3744	10	38			4896	9	38			6048	8	37
	10			4680	15	43			6120	14	44			7560	12	43

COMPUERTAS CORTAFUEGO

COMPUERTAS CORTAFUEGO RECTANGULARES

B – Ancho Nominal [mm]

v – velocidad [m/s]

Q – Caudal [m³/h]

H – Alto Nominal [mm]

Sk – Sección de los conductos [m²]

dp – Caída de Presión [Pa]

Se – Sección útil de la compuerta [m²]

L_{W/A} – Nivel de Presión sonora [dB]

		H [mm]										
		350					400					
		v [m/s]	Sk [m ²]	Se [m ²]	Q [m ³ /h]	dp [Pa]	L _{W/A} [dB]	Sk [m ²]	Se [m ²]	Q [m ³ /h]	dp [Pa]	L _{W/A} [dB]
B [mm]	200	4	0.07	0.063	900	5	26	0.08	0.073	1 044	5	26
		6			1 350	12	37			1 566	11	37
		8			1 800	21	44			2 088	19	44
		10			2 250	32	50			2 610	30	50
	250	4	0.0875	0.078	1 125	4	25	0.1	0.091	1 305	4	25
		6			1 688	10	36			1 958	9	35
		8			2 250	17	43			2 610	16	43
		10			2 813	27	49			3 263	25	49
	300	4	0.105	0.094	1 350	4	26	0.12	0.109	1 566	4	24
		6			2 025	10	36			2 349	8	35
		8			2 700	17	44			3 132	15	42
		10			3 375	27	50			3 915	23	48
	350	4	0.1225	0.109	1 575	4	25	0.14	0.127	1 827	4	25
		6			2 363	9	36			2 741	8	36
		8			3 150	15	43			3 654	15	43
		10			3 938	24	49			4 568	23	49
	400	4	0.14	0.125	1 800	3	24	0.16	0.145	2 088	3	23
		6			2 700	8	34			3 132	7	34
		8			3 600	13	42			4 176	12	41
		10			4 500	21	48			5 220	19	47
	450	4	0.1575	0.141	2 025	3	24	0.18	0.163	2 349	3	21
		6			3 038	7	34			3 524	6	32
		8			4 050	13	42			4 698	10	39
		10			5 063	20	48			5 873	16	45
	500	4	0.175	0.156	2 250	2	20	0.2	0.181	2 610	2	20
		6			3 375	5	31			3 915	5	31
		8			4 500	10	38			5 220	9	38
		10			5 625	15	44			6 525	14	44
	550	4	0.1925	0.172	2 475	2	19	0.22	0.199	2 871	2	20
		6			3 713	5	29			4 307	5	30
		8			4 950	8	37			5 742	8	38
		10			6 188	13	43			7 178	13	43
	600	4	0.21	0.188	2 700	2	18	0.24	0.218	3 132	2	19
		6			4 050	4	29			4 698	4	28
		8			5 400	8	36			6 264	7	36
		10			6 750	12	42			7 830	11	42
	650	4	0.2275	0.203	2 925	2	19	0.26	0.236	3 393	2	18
		6			4 388	4	29			5 090	4	29
		8			5 850	8	37			6 786	7	36
		10			7 313	12	42			8 483	11	42
700	4	0.245	0.219	3 150	2	18	0.28	0.254	3 654	2	18	
	6			4 725	4	28			5 481	4	29	
	8			6 300	7	36			7 308	7	36	
	10			7 875	11	42			9 135	11	42	
750	4	0.2625	0.234	3 375	2	18	0.3	0.272	3 915	2	17	
	6			5 063	4	29			5 873	4	28	
	8			6 750	7	36			7 830	6	35	
	10			8 438	11	42			9 788	10	41	
800	4	0.28	0.250	3 600	2	18	0.32	0.290	4 176	2	18	
	6			5 400	4	29			6 264	4	28	
	8			7 200	7	36			8 352	6	36	
	10			9 000	11	42			10 440	10	41	

COMPUERTAS CORTAFUEGO

COMPUERTAS CORTAFUEGO RECTANGULARES

COMPUERTA RECTANGULAR “mcr FID P”

B – Ancho Nominal [mm]

H – Alto Nominal [mm]

Se – Sección útil de la compuerta [m²]

v – velocidad [m/s]

Sk – Sección de los conductos [m²]

L_{W/A} – Nivel de Presión sonora [dB]

Q – Caudal [m³/h]

dp – Caída de Presión [Pa]

B [mm]	v [m/s]	H [mm]															
		200					250					300					
		Sk [m ²]	Se [m ²]	Q [m ³ /h]	dp [Pa]	L _{W/A} [dB]	Sk [m ²]	Se [m ²]	Q [m ³ /h]	dp [Pa]	L _{W/A} [dB]	Sk [m ²]	Se [m ²]	Q [m ³ /h]	dp [Pa]	L _{W/A} [dB]	
200	4	0.040	0.029	420	9	31	0.050	0.039	564	9	31	0.060	0.049	708	8	32	
	6			631	21	41			847	19	42			1 063	19	42	
	8			841	37	49			1 129	35	49			1 417	33	50	
	10			1 051	58	55			1 411	54	55			1 771	52	55	
	250	4	0.050	0.037	526	9	31	0.063	0.049	706	9	32	0.075	0.062	886	8	32
		6			788	21	42			1 058	19	43			1 328	18	42
		8			1 051	37	50			1 411	35	50			1 771	31	50
		10			1 314	57	55			1 764	54	56			2 214	49	56
	300	4	0.060	0.044	631	9	32	0.075	0.059	847	8	33	0.090	0.074	1 063	8	32
		6			946	20	43			1 270	19	43			1 594	17	43
		8			1 261	36	50			1 693	34	51			2 125	30	50
		10			1 577	56	56			2 117	53	56			2 657	47	56
350	4	0.070	0.051	736	9	33	0.088	0.069	988	8	33	0.105	0.086	1 240	7	32	
	6			1 104	20	43			1 482	19	44			1 860	16	43	
	8			1 472	36	51			1 976	33	51			2 480	29	50	
	10			1 840	56	57			2 470	52	57			3 100	45	56	
400	4	0.080	0.058	841	9	33	0.100	0.078	1 129	8	34	0.120	0.098	1 417	7	32	
	6			1 261	19	43			1 693	19	44			2 125	15	42	
	8			1 682	35	51			2 258	33	52			2 834	27	50	
	10			2 102	54	57			2 822	52	57			3 542	42	56	
450	4	0.090	0.066	946	9	33	0.113	0.088	1 270	7	32	0.135	0.111	1 594	7	32	
	6			1 419	19	44			1 905	17	43			2 391	15	43	
	8			1 892	35	51			2 540	29	51			3 188	27	50	
	10			2 365	54	57			3 175	46	56			3 985	42	56	
500	4	0.100	0.073	1 051	9	34	0.125	0.098	1 411	7	32	0.150	0.123	1 771	7	32	
	6			1 577	19	44			2 117	16	43			2 657	15	43	
	8			2 102	35	52			2 822	28	50			3 542	26	50	
	10			2 628	54	58			3 528	44	56			4 428	41	56	
550	4	0.110	0.080	1 156	8	34	0.138	0.108	1 552	7	33	0.165	0.135	1 948	6	33	
	6			1 734	19	44			2 328	16	43			2 922	14	43	
	8			2 313	34	52			3 105	28	51			3 897	26	51	
	10			2 891	53	58			3 881	44	57			4 871	40	56	
600	4	0.120	0.088	1 261	8	34	0.150	0.118	1 693	7	33	0.180	0.148	2 125	6	33	
	6			1 892	19	45			2 540	15	43			3 188	14	43	
	8			2 523	34	52			3 387	27	51			4 251	26	51	
	10			3 154	53	58			4 234	42	56			5 314	40	57	
650	4	0.130	0.095	1 367	8	35	0.163	0.127	1 835	6	32	0.195	0.160	2 303	6	33	
	6			2 050	19	45			2 752	14	43			3 454	14	44	
	8			2 733	34	53			3 669	26	50			4 605	26	51	
	10			3 416	53	59			4 586	40	56			5 756	40	57	
700	4	0.140	0.102	1 472	8	35	0.175	0.137	1 976	6	33	0.210	0.172	2 480	6	34	
	6			2 208	19	45			2 964	14	43			3 720	14	44	
	8			2 943	33	53			3 951	26	51			4 959	26	52	
	10			3 679	52	59			4 939	40	56			6 199	40	57	
800	4	0.160	0.117	1 682	8	35	0.200	0.157	2 258	6	32	0.240	0.197	2 834	6	33	
	6			2 523	18	45			3 387	14	43			4 251	14	44	
	8			3 364	32	53			4 516	24	51			5 668	24	52	
	10			4 205	50	59			5 645	38	56			7 085	38	57	
900	4	0.180	0.131	1 892	7	34	0.225	0.176	2 540	6	32	0.270	0.221	3 188	5	32	
	6			2 838	16	44			3 810	13	43			4 782	12	42	
	8			3 784	29	52			5 080	23	50			6 376	21	50	
	10			4 730	45	58			6 350	36	56			7 970	32	56	
1000	4	0.200	0.146	2 102	7	34	0.250	0.196	2 822	6	32	0.300	0.246	3 542	5	32	
	6			3 154	16	45			4 234	13	43			5 314	12	43	
	8			4 205	29	52			5 645	22	50			7 085	21	50	
	10			5 256	45	58			7 056	35	56			8 856	32	56	
1100	4	0.220	0.161	2 313	7	35	0.275	0.216	3 105	5	32	0.330	0.271	3 897	5	33	
	6			3 469	16	45			4 657	12	43			5 845	12	43	
	8			4 625	29	53			6 209	22	50			7 793	21	51	
	10			5 782	45	59			7 762	34	56			9 742	32	56	
1200	4	0.240	0.175	2 523	8	37	0.300	0.235	3 387	5	33	0.360	0.295	4 251	9	40	
	6			3 784	18	47			5 080	12	43			6 376	20	51	
	8			5 046	29	53			6 774	22	51			8 502	36	58	
	10			6 307	45	59			8 467	34	57			10 627	42	60	
1300	4	0.260	0.190	2 733	8	37	0.325	0.255	3 669	5	33	0.390	0.320	4 605	5	33	
	6			4 100	18	47			5 504	12	43			6 908	12	44	
	8			5 466	29	54			7 338	21	51			9 210	21	51	
	10			6 833	45	59			9 173	33	57			11 513	32	57	
1400	4	0.280	0.204	2 943	7	36	0.350	0.274	3 951	5	33	0.420	0.344	4 959	5	34	
	6			4 415	16	46			5 927	12	44			7 439	12	44	
	8			5 887	29	54			7 903	21	51			9 919	21	52	
	10			7 358	45	60			9 878	32	57			12 398	32	58	
1500	4	0.300	0.219	3 154	7	35	0.375	0.294	4 234	5	33	0.450	0.369	5 314	5	34	
	6			4 730	15	46			6 350	12	44			7 970	12	45	
	8			6 307	27	53			8 467	21	51			10 627	21	52	
	10			7 884	42	59			10 584	32	57			13 284	32	58	

COMPUERTAS CORTAFUEGO

COMPUERTAS CORTAFUEGO RECTANGULARES

B – Ancho Nominal [mm]

v – velocidad [m/s]

Q – Caudal [m³/h]

H – Alto Nominal [mm]

Sk – Sección de los conductos [m²]

dp – Caída de Presión [Pa]

Se – Sección útil de la compuerta [m²]

L_{W/A} – Nivel de Presión sonora [dB]

B [mm]	v [m/s]	H [mm]														
		350					400					450				
		Sk [m ²]	Se [m ²]	Q [m ³ /h]	dp [Pa]	L _{WA} [dB]	Sk [m ²]	Se [m ²]	Q [m ³ /h]	dp [Pa]	L _{WA} [dB]	Sk [m ²]	Se [m ²]	Q [m ³ /h]	dp [Pa]	L _{WA} [dB]
200	4	0.070	0.059	852	8	32	0.080	0.069	996	7	31	0.090	0.079	1 140	7	31
	6			1 279	18	42			1 495	17	42			1 711	15	41
	8			1 705	32	50			1 993	29	49			2 281	26	49
	10			2 131	50	56			2 491	46	55			2 851	41	54
250	4	0.088	0.074	1 066	7	31	0.100	0.087	1 246	6	29	0.113	0.099	1 426	6	29
	6			1 598	16	42			1 868	13	40			2 138	13	40
	8			2 131	29	50			2 491	23	47			2 851	22	47
	10			2 664	45	55			3 114	36	53			3 564	35	53
300	4	0.105	0.089	1 279	7	32	0.120	0.104	1 495	6	30	0.135	0.119	1 711	5	30
	6			1 918	16	43			2 242	13	41			2 566	12	40
	8			2 557	28	50			2 989	24	48			3 421	22	48
	10			3 197	44	56			3 737	37	54			4 277	34	54
350	4	0.123	0.104	1 492	7	32	0.140	0.121	1 744	6	30	0.158	0.139	1 996	5	30
	6			2 238	15	42			2 616	13	41			2 994	12	41
	8			2 984	26	50			3 488	22	48			3 992	21	48
	10			3 730	41	56			4 360	35	54			4 990	33	54
400	4	0.140	0.118	1 705	6	31	0.160	0.138	1 993	6	31	0.180	0.158	2 281	5	30
	6			2 557	13	41			2 989	13	41			3 421	12	41
	8			3 410	24	49			3 986	22	49			4 562	21	48
	10			4 262	37	55			4 982	35	55			5 702	32	54
450	4	0.158	0.133	1 918	5	30	0.180	0.156	2 242	5	30	0.203	0.178	2 566	4	29
	6			2 877	12	41			3 363	12	41			3 849	10	40
	8			3 836	22	48			4 484	21	48			5 132	18	47
	10			4 795	34	54			5 605	32	54			6 415	28	53
500	4	0.175	0.148	2 131	5	31	0.200	0.173	2 491	5	30	0.225	0.198	2 851	4	29
	6			3 197	12	41			3 737	11	40			4 277	9	39
	8			4 262	22	49			4 982	19	48			5 702	17	47
	10			5 328	34	55			6 228	30	54			7 128	26	52
550	4	0.193	0.163	2 557	5	30	0.220	0.190	2 740	5	30	0.248	0.218	3 136	4	29
	6			3 836	12	41			4 110	11	41			4 704	9	40
	8			5 115	21	48			5 481	19	48			6 273	17	47
	10			6 394	32	54			6 851	30	54			7 841	26	53
600	4	0.210	0.178	2 557	5	30	0.240	0.208	2 989	4	28	0.270	0.238	3 421	4	29
	6			3 836	10	40			4 484	8	37			5 132	9	40
	8			5 115	19	48			5 979	14	45			6 843	17	47
	10			6 394	29	53			7 474	27	53			8 554	26	53
650	4	0.228	0.192	2 771	5	30	0.260	0.225	3 239	4	30	0.293	0.257	3 707	4	30
	6			4 156	10	40			4 858	10	40			5 560	9	40
	8			5 541	19	48			6 477	17	48			7 413	17	48
	10			6 926	29	54			8 096	27	53			9 266	26	54
700	4	0.245	0.207	2 984	5	30	0.28	0.242	3 488	4	30	0.315	0.277	3 992	4	30
	6			4 476	10	41			5 232	10	40			5 988	9	40
	8			5 967	19	48			6 975	17	48			7 983	16	48
	10			7 459	29	54			8 719	27	54			9 979	25	53
800	4	0.280	0.237	3 410	4	30	0.32	0.277	3 986	4	30	0.360	0.317	4 562	4	29
	6			5 115	10	41			5 979	9	41			6 843	9	40
	8			6 820	18	48			7 972	17	48			9 124	16	47
	10			8 525	28	54			9 965	26	54			11 405	25	53
900	4	0.315	0.266	3 836	4	31	0.360	0.311	4 484	6	35	0.405	0.356	5 132	4	29
	6			5 754	10	41			6 726	12	44			7 698	9	40
	8			7 672	18	49			8 968	26	54			10 264	16	47
	10			9 590	28	55			11 210	33.4	58			12 830	25	53
1000	4	0.350	0.296	4 262	4	30	0.400	0.346	4 982	4	31	0.450	0.396	5 702	4	29
	6			6 394	9	41			7 474	9	42			8 554	9	40
	8			8 525	17	48			9 965	17	49			11 405	16	47
	10			10 656	26	54			12 456	26	55			14 256	25	53
1100	4	0.385	0.326	4 689	4	32	0.440	0.381	5 481	4	31	0.495	0.436	6 273	4	29
	6			7 033	10	42			8 221	9	42			9 409	9	39
	8			9 377	18	50			10 961	17	49			12 545	15	47
	10			11 722	28	56			13 702	26	55			15 682	24	53
1200	4	0.420	0.355	5 115	4	31	0.480	0.415	5 979	4	31	0.540	0.475	6 843	4	29
	6			7 672	9	41			8 968	9	42			10 264	9	39
	8			10 230	16	49			11 958	16	49			13 686	15	47
	10			12 787	25	54			14 947	25	55			17 107	24	53
1300	4	0.455	0.385	5 541	4	32	0.520	0.450	6 477	4	32	0.585	0.515	7 413	4	28
	6			8 312	10	43			9 716	9	42			11 120	8	39
	8			11 082	17	50			12 954	16	50			14 826	15	46
	10			13 853	27	56			16 193	25	55			18 533	23	52
1400	4	0.490	0.414	5 967	4	32	0.560	0.484	6 975	4	32	0.630	0.554	7 983	4	28
	6			8 951	10	43			10 463	9	43			11 975	8	39
	8			11 935	17	50			13 951	16	50			15 967	15	46
	10			14 918	27	56			17 438	25	56			19 958	23	52
1500	4	0.525	0.444	6 394	4	32	0.600	0.519	7 474	4	32	0.675	0.594	8 554	4	28
	6			9 590	9	43			11 210	9	43			12 830	8	38
	8			12 787	17	50			14 947	16	50			17 107	14	46
	10			15 984	26	56			18 684	25	56			21 384	22	51

COMPUERTAS CORTAFUEGO

COMPUERTAS CORTAFUEGO RECTANGULARES

B – Ancho Nominal [mm]

v – velocidad [m/s]

Q – Caudal [m³/h]

H – Alto Nominal [mm]

Sk – Sección de los conductos [m²]

dp – Caída de Presión [Pa]

Se – Sección útil de la compuerta [m²]

L_{W/A} – Nivel de Presión sonora [dB]

B [mm]	v [m/s]	H [mm]															
		500				550				600							
		Sk [m ²]	Se [m ²]	Q [m ³ /h]	dp [Pa]	L _{WA} [dB]	Sk [m ²]	Se [m ²]	Q [m ³ /h]	dp [Pa]	L _{WA} [dB]	Sk [m ²]	Se [m ²]	Q [m ³ /h]	dp [Pa]	L _{WA} [dB]	
200	4	0.100	0.089	1 284	6	29	0.110	0.099	1 428	5	29	0.120	0.109	1 572	5	29	
	6			1 927	13	40			2 143	12	39			2 359	12	39	
	8			2 569	22	47			2 857	21	47			3 145	21	47	
	10			3 211	35	53			3 571	33	53			3 931	32	53	
	250	4	0.125	0.112	1 606	6	30	0.138	0.124	1 786	5	30	0.150	0.137	1 966	5	30
		6			2 408	13	41			2 678	12	40			2 948	12	40
		8			3 211	22	48			3 571	21	48			3 931	21	48
		10			4 014	35	54			4 464	33	53			4 914	32	54
	300	4	0.150	0.134	1 927	5	30	0.165	0.149	2 143	5	30	0.180	0.164	2 359	5	30
		6			2 890	12	41			3 214	12	41			3 538	11	40
		8			3 853	21	48			4 285	21	48			4 717	19	48
		10			4 817	33	54			5 357	32	54			5 897	30	53
350	4	0.175	0.156	2 248	5	30	0.193	0.174	2 500	5	31	0.210	0.191	2 752	5	30	
	6			3 372	12	41			3 750	12	41			4 128	10	40	
	8			4 496	21	48			5 000	21	49			5 504	19	48	
	10			5 620	32	54			6 250	32	55			6 880	29	54	
400	4	0.200	0.178	2 569	5	30	0.220	0.198	2 857	5	30	0.240	0.218	3 145	4	30	
	6			3 853	11	41			4 285	10	41			4 717	10	41	
	8			5 138	19	48			5 714	19	48			6 290	18	48	
	10			6 422	30	54			7 142	29	54			7 862	28	54	
450	4	0.225	0.201	2 890	4	29	0.248	0.223	3 214	4	29	0.270	0.246	3 538	4	30	
	6			4 335	9	39			4 821	9	40			5 307	9	40	
	8			5 780	17	47			6 428	17	47			7 076	17	48	
	10			7 225	26	52			8 035	26	53			8 845	26	53	
500	4	0.250	0.223	3 211	4	27	0.275	0.248	3 571	4	29	0.300	0.273	3 931	4	29	
	6			4 817	8	38			5 357	9	39			5 897	9	39	
	8			6 422	14	45			7 142	15	47			7 862	15	47	
	10			8 028	20	50			8 928	24	52			9 828	24	53	
550	4	0.275	0.245	3 853	3	27	0.303	0.273	4 285	4	28	0.330	0.300	4 717	4	28	
	6			5 780	8	37			6 428	8	38			7 076	8	39	
	8			7 707	13	45			8 571	14	46			9 435	14	46	
	10			9 634	21	51			10 714	22	52			11 794	22	52	
600	4	0.300	0.268	3 853	3	27	0.330	0.298	4 285	3	28	0.360	0.328	4 717	3	28	
	6			5 780	8	38			6 428	8	38			7 076	8	39	
	8			7 707	13	45			8 571	13	46			9 435	13	46	
	10			9 634	21	51			10 714	21	51			11 794	21	52	
650	4	0.325	0.290	4 175	4	31	0.358	0.322	4 643	3	28	0.390	0.355	5 111	3	28	
	6			6 262	10	41			6 964	8	38			7 666	8	39	
	8			8 349	17	49			9 285	13	46			10 221	13	46	
	10			10 436	21	51			11 606	21	52			12 776	21	52	
700	4	0.350	0.312	4 496	3	28	0.385	0.347	5 000	3	28	0.420	0.382	5 504	3	29	
	6			6 744	8	38			7 500	8	39			8 256	8	39	
	8			8 991	13	46			9 999	13	46			11 007	13	47	
	10			11 239	21	52			12 499	21	52			13 759	21	52	
800	4	0.400	0.357	5 138	3	28	0.440	0.397	5 714	3	29	0.480	0.437	6 290	3	29	
	6			7 707	8	39			8 571	8	39			9 435	8	40	
	8			10 276	13	46			11 428	13	47			12 580	13	47	
	10			12 845	21	52			14 285	21	53			15 725	21	53	
900	4	0.450	0.401	5 780	3	28	0.495	0.446	6 428	3	29	0.540	0.491	7 076	3	30	
	6			8 670	8	39			9 642	8	40			10 614	8	38	
	8			11 560	13	46			12 856	13	47			14 152	13	45	
	10			14 450	21	52			16 070	21	53			17 690	21	51	
1000	4	0.500	0.446	6 422	3	28	0.550	0.496	6 428	3	30	0.600	0.546	7 862	3	30	
	6			9 634	8	39			9 642	8	40			11 794	8	41	
	8			12 845	13	46			12 856	13	48			15 725	13	48	
	10			16 056	21	52			16 070	21	54			19 656	21	54	
1100	4	0.550	0.491	7 065	4	29	0.605	0.546	7 857	4	31	0.660	0.601	8 649	3	31	
	6			10 597	8	39			11 785	8	41			12 973	8	41	
	8			14 129	14	47			15 713	14	49			17 297	13	49	
	10			17 662	22	53			19 642	22	55			21 622	21	54	
1200	4	0.600	0.535	7 707	3	27	0.660	0.595	8 571	3	30	0.720	0.655	9 435	3	30	
	6			11 560	7	38			12 856	7	40			14 152	7	40	
	8			15 414	13	45			17 142	13	48			18 870	12	48	
	10			19 267	20	51			21 427	20	54			23 587	19	54	
1300	4	0.650	0.580	8 349	3	27	0.715	0.645	9 285	3	30	0.780	0.710	10 221	3	30	
	6			12 524	7	38			13 928	7	41			15 332	7	41	
	8			16 698	13	45			18 570	13	48			20 442	12	48	
	10			20 873	20	51			23 213	20	54			25 553	19	54	
1400	4	0.700	0.624	8 991	3	27	0.770	0.694	9 999	3	31	0.840	0.764	11 007	3	30	
	6			13 487	7	38			14 999	7	41			16 511	7	41	
	8			17 983	13	45			19 999	13	49			22 015	12	48	
	10			22 478	20	51			24 998	20	54			27 518	19	54	
1500	4	0.750	0.669	9 634	3	27	0.825	0.744	10 714	3	31	0.900	0.819	11 794	3	31	
	6			14 450	7	38			16 070	7	41			17 690	7	41	
	8			19 267	13	45			21 427	13	49			23 587	12	49	
	10			24 084	20	51			26 784	20	55			29 484	19	54	

COMPUERTAS CORTAFUEGO

COMPUERTAS CORTAFUEGO RECTANGULARES

B – Ancho Nominal [mm]

v – velocidad [m/s]

Q – Caudal [m³/h]

H – Alto Nominal [mm]

Sk – Sección de los conductos [m²]

dp – Caída de Presión [Pa]

Se – Sección útil de la compuerta [m²]

L_{WA} – Nivel de Presión sonora [dB]

B [mm]	v [m/s]	H [mm]															
		650					700					750					
		Sk [m ²]	Se [m ²]	Q [m ³ /h]	dp [Pa]	L _{WA} [dB]	Sk [m ²]	Se [m ²]	Q [m ³ /h]	dp [Pa]	L _{WA} [dB]	Sk [m ²]	Se [m ²]	Q [m ³ /h]	dp [Pa]	L _{WA} [dB]	
200	4	0.130	0.119	1 716	5	29	0.140	0.129	1 860	5	29	0.150	0.139	2 004	5	29	
	6			2 575	11	39			2 791	11	40			3 007	11	40	
	8			3 433	20	47			3 721	20	47			4 009	20	47	
	10			4 291	31	53			4 651	31	53			5 011	31	53	
	250	4	0.163	0.149	2 146	5	30	0.175	0.162	2 326	5	30	0.188	0.174	2 506	5	30
		6			3 218	11	40			3 488	11	41			3 758	11	41
		8			4 291	20	48			4 651	20	48			5 011	20	48
		10			5 364	31	53			5 814	31	54			6 264	31	54
	300	4	0.195	0.179	2 575	5	30	0.210	0.194	2 791	4	29	0.225	0.209	3 007	4	30
		6			3 862	10	40			4 186	10	40			4 510	10	40
		8			5 149	19	48			5 581	18	47			6 013	18	48
		10			6 437	29	53			6 977	28	53			7 517	28	54
350	4	0.228	0.209	3 004	4	30	0.245	0.226	3 256	4	30	0.263	0.244	3 508	4	30	
	6			4 506	10	40			4 884	10	40			5 262	10	41	
	8			6 008	18	48			6 512	17	48			7 016	17	48	
	10			7 510	28	54			8 140	27	53			8 770	27	54	
400	4	0.260	0.238	3 433	4	30	0.280	0.258	3 721	4	30	0.300	0.278	4 009	4	31	
	6			5 149	10	41			5 581	10	41			6 013	10	41	
	8			6 866	18	48			7 442	17	48			8 018	17	49	
	10			8 582	28	54			9 302	27	54			10 022	27	54	
450	4	0.293	0.268	3 862	4	30	0.315	0.291	4 186	4	29	0.338	0.313	4 510	4	30	
	6			5 793	9	40			6 279	9	40			6 765	9	40	
	8			7 724	17	48			8 372	15	47			9 020	15	48	
	10			9 655	26	54			10 465	24	53			11 275	24	53	
500	4	0.325	0.298	4 291	4	29	0.350	0.323	4 651	4	29	0.375	0.348	5 011	4	29	
	6			6 437	9	40			6 977	8	40			7 517	8	40	
	8			8 582	15	47			9 302	15	47			10 022	15	47	
	10			10 728	24	53			11 628	23	53			12 528	23	53	
550	4	0.358	0.328	5 149	4	29	0.385	0.355	5 116	4	29	0.413	0.383	5 512	4	29	
	6			7 724	8	39			7 674	8	39			8 268	8	40	
	8			10 299	14	47			10 233	14	47			11 025	14	47	
	10			12 874	22	52			12 791	22	53			13 781	22	53	
600	4	0.390	0.358	5 149	3	28	0.420	0.388	5 581	3	29	0.450	0.418	6 013	3	29	
	6			7 724	8	39			8 372	8	39			9 020	8	40	
	8			10 299	13	46			11 163	13	47			12 027	13	47	
	10			12 874	21	52			13 954	21	53			15 034	21	53	
650	4	0.423	0.387	5 579	3	28	0.455	0.420	6 047	3	28	0.488	0.452	6 515	3	28	
	6			8 368	7	39			9 070	7	39			9 772	7	39	
	8			11 157	13	46			12 093	13	46			13 029	12	46	
	10			13 946	20	52			15 116	20	52			16 286	19	52	
700	4	0.455	0.417	6 008	3	28	0.490	0.452	6 512	3	29	0.525	0.487	7 016	3	28	
	6			9 012	7	39			9 768	7	39			10 524	7	39	
	8			12 015	13	46			13 023	13	47			14 031	12	46	
	10			15 019	20	52			16 279	20	53			17 539	19	52	
800	4	0.520	0.477	6 866	3	27	0.560	0.517	7 442	4	29	0.600	0.557	8 018	3	28	
	6			10 299	6	38			11 163	7	37			12 027	6	39	
	8			13 732	12	45			14 884	11	43			16 036	12	46	
	10			17 165	18	51			18 605	16	47			20 045	18	52	
900	4	0.585	0.536	7 724	3	26	0.630	0.581	8 372	3	27	0.675	0.626	9 020	3	27	
	6			11 586	6	36			12 558	6	37			13 530	6	38	
	8			15 448	10	44			16 744	10	45			18 040	10	45	
	10			19 310	16	50			20 930	16	51			22 550	16	51	
1000	4	0.650	0.596	8 582	3	26	0.700	0.646	9 302	3	27	0.750	0.696	10 022	3	28	
	6			12 874	6	36			13 954	6	38			15 034	6	38	
	8			17 165	10	44			18 605	10	45			20 045	10	46	
	10			21 456	16	50			23 256	16	51			25 056	16	52	
1100	4	0.715	0.656	9 441	3	29	0.770	0.711	10 233	3	31	0.825	0.766	11 025	3	28	
	6			14 161	8	40			15 349	8	42			16 537	6	39	
	8			18 881	13	47			20 465	13	49			22 049	10	46	
	10			23 602	21	53			25 582	21	55			27 562	16	52	
1200	4	0.780	0.715	10 299	3	28	0.840	0.775	11 163	3	30	0.900	0.835	12 027	2	28	
	6			15 448	7	39			16 744	7	41			18 040	5	38	
	8			20 598	12	46			22 326	12	48			24 054	10	46	
	10			25 747	19	52			27 907	19	54			30 067	15	52	
1300	4	0.845	0.775	11 157	3	28	0.910	0.840	12 093	3	31	0.975	0.905	13 029	2	28	
	6			16 736	7	39			18 140	7	41			19 544	5	39	
	8			22 314	12	46			24 186	12	49			26 058	10	46	
	10			27 893	19	52			30 233	19	55			32 573	15	52	
1400	4	0.910	0.834	12 015	3	28	0.980	0.904	13 023	3	31	1.050	0.974	14 031	2	28	
	6			18 023	7	39			19 535	7	42			21 047	5	39	
	8			24 031	12	46			26 047	12	49			28 063	10	46	
	10			30 038	19	52			32 558	19	55			35 078	15	52	
1500	4	0.975	0.894	12 874	3	28	1.050	0.969	13 954	3	31	1.125	1.044	15 034	3	30	
	6			19 310	7	39			20 930	7	42			22 550	6	41	
	8			25 747	12	46			27 907	12	49			30 067	11	48	
	10			32 184	19	52			34 884	19	55			37 584	17	54	

COMPUERTAS CORTAFUEGO

COMPUERTAS CORTAFUEGO RECTANGULARES

B – Ancho Nominal [mm]

v – velocidad [m/s]

Q – Caudal [m³/h]

H – Alto Nominal [mm]

Sk – Sección de los conductos [m²]

dp – Caída de Presión [Pa]

Se – Sección útil de la compuerta [m²]

L_{W/A} – Nivel de Presión sonora [dB]

B [mm]	v [m/s]	H [mm]															
		800					850					900					
		Sk [m ²]	Se [m ²]	Q [m ³ /h]	dp [Pa]	L _{W/A} [dB]	Sk [m ²]	Se [m ²]	Q [m ³ /h]	dp [Pa]	L _{W/A} [dB]	Sk [m ²]	Se [m ²]	Q [m ³ /h]	dp [Pa]	L _{W/A} [dB]	
200	4	0.160	0.149	2 148	5	29	0.170	0.159	2 292	5	29	0.180	0.169	2 436	5	30	
	6			3 223	11	40			3 439	11	40			3 655	11	40	
	8			4 297	19	47			4 585	19	48			4 873	19	48	
	10			5 371	30	53			5 731	30	53			6 091	30	54	
	250	4	0.200	0.187	2 686	5	30	0.213	0.199	2 866	5	30	0.225	0.212	3 046	5	31
		6			4 028	11	41			4 298	11	41			4 568	11	41
		8			5 371	19	48			5 731	19	49			6 091	19	49
		10			6 714	30	54			7 164	30	54			7 614	30	55
	300	4	0.240	0.224	3 223	4	30	0.255	0.239	3 439	4	30	0.270	0.254	3 655	4	30
		6			4 834	10	41			5 158	10	41			5 482	10	41
		8			6 445	18	48			6 877	18	48			7 309	17	48
		10			8 057	28	54			8 597	28	54			9 137	27	54
350	4	0.280	0.261	3 760	4	30	0.298	0.279	4 012	4	31	0.315	0.296	4 264	4	30	
	6			5 640	10	41			6 018	10	41			6 396	9	41	
	8			7 520	17	48			8 024	17	49			8 528	17	48	
	10			9 400	27	54			10 030	27	54			10 660	26	54	
400	4	0.320	0.298	4 297	4	31	0.340	0.318	4 585	4	31	0.360	0.338	4 873	4	30	
	6			6 445	10	41			6 877	10	42			7 309	9	41	
	8			8 594	17	49			9 170	17	49			9 746	16	48	
	10			10 742	27	55			11 462	27	55			12 182	25	54	
450	4	0.360	0.336	4 834	4	29	0.383	0.358	5 158	4	29	0.405	0.381	5 482	3	29	
	6			7 251	8	39			7 737	8	40			8 223	8	39	
	8			9 668	14	47			10 316	14	47			10 964	13	47	
	10			12 085	22	53			12 895	22	53			13 705	21	52	
500	4	0.400	0.373	5 371	4	29	0.425	0.398	5 731	4	29	0.450	0.423	6 091	3	29	
	6			8 057	8	40			8 597	8	40			9 137	8	40	
	8			10 742	14	47			11 462	14	47			12 182	13	47	
	10			13 428	22	53			14 328	22	53			15 228	21	53	
550	4	0.440	0.410	5 908	3	29	0.468	0.438	6 304	3	29	0.495	0.465	6 700	3	29	
	6			8 862	8	40			9 456	8	40			10 050	7	39	
	8			11 817	13	47			12 609	13	47			13 401	13	47	
	10			14 771	21	53			15 761	21	53			16 751	20	53	
600	4	0.480	0.448	6 445	3	29	0.510	0.478	6 877	3	29	0.540	0.508	7 309	3	29	
	6			9 668	7	39			10 316	7	40			10 964	7	39	
	8			12 891	13	47			13 755	13	47			14 619	12	47	
	10			16 114	20	53			17 194	20	53			18 274	19	52	
650	4	0.520	0.485	6 983	3	28	0.553	0.517	7 451	3	29	0.585	0.550	7 919	3	29	
	6			10 474	7	39			11 176	7	39			11 878	7	39	
	8			13 965	12	46			14 901	12	47			15 837	12	47	
	10			17 456	19	52			18 626	19	53			19 796	19	53	
700	4	0.560	0.522	7 520	3	28	0.595	0.557	8 024	3	28	0.630	0.592	8 528	3	27	
	6			11 280	6	39			12 036	6	39			12 792	6	38	
	8			15 039	12	46			16 047	12	46			17 055	10	45	
	10			18 799	18	52			20 059	18	52			21 319	16	51	
800	4	0.640	0.597	8 594	3	27	0.680	0.637	9 170	3	27	0.720	0.677	9 746	3	28	
	6			12 891	6	38			13 755	6	38			14 619	6	38	
	8			17 188	10	45			18 340	10	45			19 492	10	46	
	10			21 485	16	51			22 925	16	51			24 365	16	51	
900	4	0.720	0.671	9 668	3	28	0.765	0.716	10 316	3	28	0.810	0.761	10 964	3	28	
	6			14 502	6	38			15 474	6	38			16 446	6	39	
	8			19 336	10	46			20 632	10	46			21 928	10	46	
	10			24 170	16	51			25 790	16	52			27 410	16	52	
1000	4	0.800	0.746	10 742	3	28	0.850	0.796	11 462	3	28	0.900	0.846	12 182	3	29	
	6			16 114	6	39			17 194	6	39			18 274	6	39	
	8			21 485	10	46			22 925	10	46			24 365	10	47	
	10			26 856	16	52			28 656	16	52			30 456	16	52	
1100	4	0.880	0.821	11 817	3	28	0.935	0.876	12 609	3	29	0.990	0.931	13 401	3	29	
	6			17 725	6	39			18 913	6	39			20 101	6	40	
	8			23 633	10	46			25 217	10	47			26 801	10	47	
	10			29 542	16	52			31 522	16	53			33 502	16	53	
1200	4	0.960	0.895	12 891	2	28	1.020	0.955	13 755	2	28	1.080	1.015	14 619	2	28	
	6			19 336	5	39			20 632	5	39			21 928	5	38	
	8			25 782	10	46			27 510	10	46			29 238	9	46	
	10			32 227	15	52			34 387	15	52			36 547	14	51	
1300	4	1.040	0.970	13 965	2	28	1.105	1.035	14 901	2	29	1.170	1.100	15 837	2	29	
	6			20 948	5	39			22 352	5	39			23 756	5	39	
	8			27 930	10	46			29 802	10	47			31 674	10	47	
	10			34 913	15	52			37 253	15	52			39 593	15	53	
1400	4	1.120	1.044	15 039	2	29	1.190	1.114	16 047	3	30	1.260	1.184	17 055	2	28	
	6			22 559	5	39			24 071	6	40			25 583	5	39	
	8			30 079	10	47			32 095	10	48			34 111	9	46	
	10			37 598	15	52			40 118	16	54			42 638	14	52	
1500	4	1.200	1.119	16 114	3	31	1.275	1.194	17 194	3	30	1.350	1.269	18 274	2	29	
	6			24 170	6	41			25 790	6	41			27 410	5	40	
	8			32 227	11	49			34 387	10	48			36 547	10	48	
	10			40 284	17	54			42 984	16	54			45 684	15	53	

COMPUERTAS CORTAFUEGO

COMPUERTAS CORTAFUEGO RECTANGULARES

B – Ancho Nominal [mm]

v – velocidad [m/s]

Q – Caudal [m³/h]

H – Alto Nominal [mm]

Sk – Sección de los conductos [m²]

dp – Caída de Presión [Pa]

Se – Sección útil de la compuerta [m²]

L_{W/A} – Nivel de Presión sonora [dB]

B [mm]	v [m/s]	H [mm]															
		1000					1100					1200					
		Sk [m ²]	Se [m ²]	Q [m ³ /h]	dp [Pa]	L _{W/A} [dB]	Sk [m ²]	Se [m ²]	Q [m ³ /h]	dp [Pa]	L _{W/A} [dB]	Sk [m ²]	Se [m ²]	Q [m ³ /h]	dp [Pa]	L _{W/A} [dB]	
200	4	0.200	0.189	2 724	5	30	0.220	0.209	3 012	5	30	0.240	0.229	3 300	4	30	
	6			4 087	10	40			4 519	10	41			4 951	10	41	
	8			5 449	19	48			6 025	19	48			6 601	18	48	
	10			6 811	29	54			7 531	29	54			8 251	28	54	
	250	4	0.250	0.237	3 406	5	31	0.275	0.262	3 766	4	31	0.300	0.287	4 126	4	31
		6			5 108	10	41			5 648	10	41			6 188	10	41
		8			6 811	19	49			7 531	18	49			8 251	17	49
		10			8 514	29	55			9 414	28	55			10 314	27	55
	300	4	0.300	0.284	4 087	4	31	0.330	0.314	4 519	4	31	0.360	0.344	4 951	4	31
		6			6 130	10	41			6 778	10	42			7 426	9	42
		8			8 173	17	49			9 037	17	49			9 901	17	49
		10			10 217	27	54			11 297	27	55			12 377	26	55
350	4	0.350	0.331	4 768	4	31	0.385	0.366	5 272	4	31	0.420	0.401	5 776	4	31	
	6			7 152	9	41			7 908	9	42			8 664	9	41	
	8			9 536	17	49			10 544	17	49			11 552	15	49	
	10			11 920	26	55			13 180	26	55			14 440	24	54	
400	4	0.400	0.378	5 449	3	28	0.440	0.418	6 025	3	28	0.480	0.458	6 601	3	29	
	6			8 173	7	39			9 037	7	39			9 901	7	39	
	8			10 898	13	46			12 050	13	46			13 202	13	47	
	10			13 622	20	52			15 062	20	52			16 502	20	53	
450	4	0.450	0.426	6 130	3	28	0.495	0.471	6 778	3	29	0.540	0.516	7 426	3	29	
	6			9 195	7	39			10 167	7	39			11 139	7	40	
	8			12 260	13	47			13 556	13	47			14 852	13	47	
	10			15 325	20	52			16 945	20	53			18 565	20	53	
500	4	0.500	0.473	6 811	3	29	0.550	0.523	7 531	3	29	0.600	0.573	8 251	3	30	
	6			10 217	7	39			11 297	7	40			12 377	7	40	
	8			13 622	13	47			15 062	13	47			16 502	13	48	
	10			17 028	20	53			18 828	20	53			20 628	20	54	
550	4	0.550	0.520	7 492	3	29	0.605	0.575	8 284	3	30	0.660	0.630	9 076	3	30	
	6			11 238	7	40			12 426	7	40			13 614	7	41	
	8			14 985	13	47			16 569	13	48			18 153	13	48	
	10			18 731	20	53			20 711	20	54			22 691	20	54	
600	4	0.600	0.568	8 173	3	29	0.660	0.628	9 037	3	29	0.720	0.688	9 901	3	29	
	6			12 260	7	40			13 556	6	39			14 852	6	40	
	8			16 347	12	47			18 075	12	47			19 803	12	47	
	10			20 434	19	53			22 594	18	53			24 754	18	53	
650	4	0.650	0.615	8 855	3	29	0.715	0.680	9 791	3	29	0.780	0.745	10 727	3	30	
	6			13 282	7	40			14 686	6	40			16 090	6	40	
	8			17 709	12	47			19 581	12	47			21 453	12	48	
	10			22 136	19	53			24 476	18	53			26 816	18	53	
700	4	0.700	0.662	9 536	3	27	0.770	0.732	10 544	2	27	0.840	0.802	11 552	2	27	
	6			14 304	6	38			15 816	5	38			17 328	5	38	
	8			19 071	10	46			21 087	10	45			23 103	10	46	
	10			23 839	16	51			26 359	15	51			28 879	15	51	
800	4	0.800	0.757	10 898	3	28	0.880	0.837	12 050	2	28	0.960	0.917	13 202	2	28	
	6			16 347	6	39			18 075	5	38			19 803	5	39	
	8			21 796	10	46			24 100	10	46			26 404	10	46	
	10			27 245	16	52			30 125	15	52			33 005	15	52	
900	4	0.900	0.851	12 260	3	29	0.990	0.941	13 556	3	29	1.080	1.031	14 852	2	29	
	6			18 390	6	39			20 334	6	40			22 278	5	39	
	8			24 520	10	47			27 112	10	47			29 704	10	47	
	10			30 650	16	52			33 890	16	53			37 130	15	52	
1000	4	1.000	0.946	13 622	3	29	1.100	1.046	15 062	2	29	1.200	1.146	16 502	2	28	
	6			20 434	6	40			22 594	5	39			24 754	5	39	
	8			27 245	10	47			30 125	10	47			33 005	9	46	
	10			34 056	16	53			37 656	15	52			41 256	14	52	
1100	4	1.100	1.041	14 985	3	29	1.210	1.151	16 569	2	29	1.320	1.261	18 153	2	29	
	6			22 477	6	40			24 853	5	40			27 229	5	39	
	8			29 969	10	48			33 137	10	47			36 305	9	47	
	10			37 462	16	53			41 422	15	53			45 382	14	52	
1200	4	1.200	1.135	16 347	2	28	1.320	1.255	18 075	10	47	1.440	1.375	19 803	2	28	
	6			24 520	5	39			27 112	22	58			29 704	5	39	
	8			32 694	9	46			36 150	38	66			39 606	8	46	
	10			40 867	14	52			45 187	14	52			49 507	13	52	
1300	4	1.300	1.230	17 709	2	28	1.430	1.360	19 581	2	28	1.560	1.490	21 453	2	28	
	6			26 564	5	39			29 372	5	38			32 180	5	39	
	8			35 418	9	46			39 162	8	46			42 906	8	46	
	10			44 273	14	52			48 953	13	52			53 633	13	52	
1400	4	1.400	1.324	19 071	2	29	1.540	1.464	21 087	2	28	1.680	1.604	23 103	2	28	
	6			28 607	5	39			31 631	5	39			34 655	4	38	
	8			38 143	9	47			42 175	8	46			46 207	8	46	
	10			47 678	14	53			52 718	13	52			57 758	12	51	
1500	4	1.500	1.419	20 434	2	28	1.650	1.569	22 594	2	29	1.800	1.719	24 754	2	28	
	6			30 650	5	39			33 890	5	39			37 130	4	38	
	8			40 867	8	46			45 187	8	47			49 507	8	46	
	10			51 084	13	52			56 484	13	52			61 884	12	52	

COMPUERTAS CORTAFUEGO

COMPUERTAS CORTAFUEGO RECTANGULARES

B – Ancho Nominal [mm]

v – velocidad [m/s]

Q – Caudal [m³/h]

H – Alto Nominal [mm]

Sk – Sección de los conductos [m²]

dp – Caída de Presión [Pa]

Se – Sección útil de la compuerta [m²]

L_{WA} – Nivel de Presión sonora [dB]

B [mm]	v [m/s]	H [mm]																																				
		1300					1400					1500																										
		Sk [m ²]	Se [m ²]	Q [m ³ /h]	dp [Pa]	L _{WA} [dB]	Sk [m ²]	Se [m ²]	Q [m ³ /h]	dp [Pa]	L _{WA} [dB]	Sk [m ²]	Se [m ²]	Q [m ³ /h]	dp [Pa]	L _{WA} [dB]																						
200	4	0.260	0.249	3 588	4	30	0.280	0.269	3 876	4	29	0.300	0.289	4 164	4	29																						
	6			5 383	9	40			5 815	9	40			6 247	9	40																						
	8			7 177	17	48			7 753	16	47			8 329	15	47																						
	10			8 971	26	53			9 691	25	53			10 411	24	53																						
250	4	0.325	0.312	4 486	4	31	0.350	0.337	4 846	4	30	0.375	0.362	5 164	4	30																						
	6			6 728	9	41			7 268	9	40			7 847	8	40																						
	8			8 971	17	49			9 691	15	48			10 411	15	48																						
	10			11 214	26	54			12 114	24	54			13 014	23	53																						
300	4	0.390	0.374	5 383	4	31	0.420	0.404	5 815	4	31	0.450	0.434	6 247	4	30																						
	6			8 074	9	41			8 722	9	41			9 370	8	40																						
	8			10 765	16	49			11 629	15	49			12 493	14	48																						
	10			13 457	25	55			14 537	24	54			15 617	22	54																						
350	4	0.455	0.436	6 280	4	30	0.490	0.471	6 784	3	30	0.525	0.506	7 288	3	30																						
	6			9 420	8	41			10 176	8	40			10 932	8	40																						
	8			12 560	15	48			13 568	13	48			14 576	13	48																						
	10			15 700	23	54			16 960	21	53			18 220	21	54																						
400	4	0.520	0.498	7 177	3	29	0.560	0.538	7 753	3	29	0.600	0.578	8 329	3	30																						
	6			10 765	7	40			11 629	7	40			12 493	7	40																						
	8			14 354	13	47			15 506	13	48			16 658	13	48																						
	10			17 942	20	53			19 382	20	53			20 822	20	54																						
450	4	0.585	0.561	8 074	3	29	0.630	0.606	8 722	3	29	0.675	0.651	9 370	3	30																						
	6			12 111	7	40			13 083	7	40			14 055	7	40																						
	8			16 148	12	47			17 444	12	47			18 740	12	48																						
	10			20 185	19	53			21 805	19	53			23 425	19	53																						
500	4	0.650	0.623	8 971	3	29	0.700	0.673	9 691	3	30	0.750	0.723	10 411	3	30																						
	6			13 457	7	40			14 537	7	40			15 617	7	41																						
	8			17 942	12	48			19 382	12	48			20 822	12	48																						
	10			22 428	19	53			24 228	19	54			26 028	19	54																						
550	4	0.715	0.685	9 868	3	30	0.770	0.740	10 660	3	30	0.825	0.795	11 452	3	31																						
	6			14 802	7	40			15 990	7	41			17 178	7	41																						
	8			19 737	12	48			21 321	12	48			22 905	12	49																						
	10			24 671	19	54			26 651	19	54			28 631	19	54																						
600	4	0.780	0.748	10 765	3	29	0.840	0.808	11 629	3	29	0.900	0.868	12 493	3	29																						
	6			16 148	6	39			17 444	6	40			18 740	6	40																						
	8			21 531	11	47			23 259	11	47			24 987	11	48																						
	10			26 914	17	53			29 074	17	53			31 234	17	53																						
650	4	0.845	0.810	11 663	3	29	0.910	0.875	12 599	3	29	0.975	0.940	13 535	3	30																						
	6			17 494	6	40			18 898	6	40			20 302	6	40																						
	8			23 325	11	47			25 197	11	48			27 069	11	48																						
	10			29 156	17	53			31 496	17	53			33 836	17	54																						
700	4	0.910	0.872	12 560	2	28	0.980	0.942	13 568	2	28	1.050	1.012	14 576	2	28																						
	6			18 840	5	38			20 352	5	39			21 864	5	39																						
	8			25 119	10	46			27 135	10	46			29 151	10	47																						
	10			31 399	15	52			33 919	15	52			36 439	15	52																						
800	4	1.040	0.997	14 354	2	28	1.120	1.077	15 506	2	29	1.200	1.157	16 658	2	29																						
	6			21 531	5	39			23 259	5	39			24 987	5	40																						
	8			28 708	10	46			31 012	10	47			33 316	10	47																						
	10			35 885	15	52			38 765	15	53			41 645	15	53																						
900	4	1.170	1.121	16 148	2	29	1.260	1.211	17 444	2	29	1.350	1.301	18 740	2	30																						
	6			24 222	5	39			26 166	5	40			28 110	5	40																						
	8			32 296	10	47			34 888	10	47			37 480	10	48																						
	10			40 370	15	53			43 610	15	53			46 850	15	53																						
1000	4	1.300	1.246	17 942	2	28	1.400	1.346	19 382	2	28	1.500	1.446	20 822	2	28																						
	6			26 914	5	39			29 074	5	38			31 234	5	39																						
	8			35 885	9	47			38 765	8	46			41 645	8	46																						
	10			44 856	14	52			48 456	13	52			52 056	13	52																						
1100	4	1.430	1.371	19 737	2	29	1.540	1.481	21 321	2	27	1.650	1.591	22 905	2	26																						
	6			29 605	5	39			31 981	4	38			34 357	4	37																						
	8			39 473	9	47			42 641	8	45			45 809	7	44																						
	10			49 342	14	53			53 302	12	51			57 262	11	50																						
1200	4	1.560	1.495	21 531	2	28	1.680	1.615	23 259	2	28	1.800	1.735	24 987	2	26																						
	6			32 296	5	39			34 888	4	38			37 480	4	36																						
	8			43 062	8	46			46 518	8	46			49 974	6	44																						
	10			53 827	13	52			58 147	12	51			62 467	10	49																						
1300	4	1.690	1.620	23 325	2	28	1.820	1.750	25 197	2	27																											
	6			34 988	4	38			37 796	4	37																											
	8			46 650	8	46			50 394	7	45																											
	10			58 313	12	51			62 993	11	51																											
1400	4	1.820	1.744	25 119	2	28																																
	6			37 679	4	39																																
	8			50 239	8	46																																
	10			62 798	12	52																																